

FICHE PRODUIT
— VERTIGO —
Suspensions / *Pendant lamp*

CONSTANCE GUISET

CONSTANCE GUISSET

FRANÇAISE / FRENCH - 2010



Née en 1976, Constance Guisset vit et travaille à Paris. Constance Guisset est une designer française au parcours original. Après des études économiques et commerciales à l'ESSEC et à l'IEP Paris, puis une année au Parlement de Tokyo, elle choisit de se tourner vers la création. Elle est diplômée en 2007 de l'ENSCI - Les Ateliers et fonde son studio. Elle obtient rapidement différentes reconnaissances telles que le Grand Prix du Design de la Ville de Paris en 2008, le Prix du Public à la Design Parade de la Villa Noailles en 2009, le titre de Designer de l'année au Salon Maison et Objets et le Audi Talents Awards en 2010. Ses différents champs de recherche l'amènent à travailler avec Petite Friture, Fontana Arte, Molteni... pour le design produit; avec Angelin Preljocaj, Established & Sons et les galeries Lafayette notamment en scénographie; et avec le musée des arts décoratif et la Biennale du design de Saint-Etienne dans le domaine de la vidéo.

« Mes recherches trouvent des applications multiples en scénographie, design d'objets et vidéos. Je m'attache à créer des objets légers, animés, dont l'élégante fluidité suscite l'étonnement et l'évasion par le rêve. » CONSTANCE GUISSET

Autres produits / Other products :

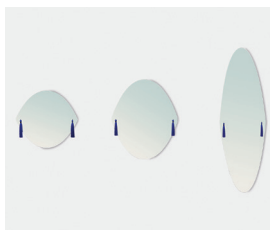

PANACHE
MIRROIRS / MIRRORS



FRANCIS
MIRROIRS / MIRRORS



NUBILO
CANAPÉ & FAUTEUIL / SOFA & ARMCHAIR

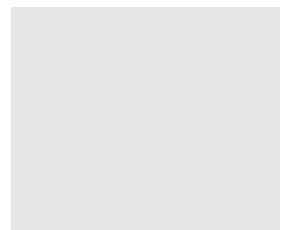

Born in 1976, Constance Guisset lives and works in Paris. Constance Guisset is a French designer with an original story. After studying economics and business at ESSEC and IEP in Paris, followed by a year in the parliament in Tokyo she chose to focus on design. In 2007 she graduated from ENSCI - Les Ateliers and founded her studio. She quickly earned recognition through winning prizes such as the Grand Prix du Design de la ville de Paris in 2008, the public prize at the Design Parade in Villa Noailles 2009, and finally in 2010 both the designer of the year at Maison et Objet, and the Audi Talent Awards. Her different research paths have led her to work with Petite Friture, Fontana Arte and Molteni amongst others for product design. In addition she has worked with Angelin Preljocaj, Established & Sons and Galleries Lafayette notably working with the latter on scenography, and has worked with video for Le Musée des Arts Décoratifs and the design Biennale in Saint-Étienne.

« My research finds multiple applications in scenography, object design and videos. I attach myself to creating light, animated objects in which the elegant fluidity creates surprise and evasion through dreaming. » CONSTANCE GUISSET

VERTIGO
SUSPENSIONS / PENDANT LAMPS
 CONSTANCE GUISSET

Creation **2010**

Edition **2010**

Récompences / Reward : LABEL VIA 2010
 CNAP 2015



VERTIGO...

VERTIGO est une « lampe cabane », selon les termes mêmes de son designer; à la fois aérienne et graphique, elle s'adapte aux grands volumes comme aux petits, où elle recrée un espace propre et intime. Structure ultralégère en fibre de verre, mise en tension par des rubans polyuréthanes au toucher velouté, cette suspension exerce une vraie fascination quand elle s'anime et prend vie au gré des courants d'air.

VU PAR SON DESIGNER :

« *Mouvement, illusion, légèreté, surprise. VERTIGO est une suspension qui suggère un espace d'intimité graphique et transparent qui s'anime au gré des courants d'air.* » CONSTANCE GUISSET

COMMERCIAL TEXT :

VERTIGO is, in the words of its designer, a "den lamp". It is simultaneously ethereal and graphic, adapting to both large and small spaces where it creates it's own intimate space. With its ultra-light fibreglass structure, stretched with velvety polyurethane ribbons, this pendant lamp fascinates as it comes to life swaying in the soft air currents that surround it.

ACCORDING TO ITS DESIGNER :

« *VERTIGO is a den-lamp; it wraps around you, reducing space to an intimate atmosphere. Due to its extreme lightness, air currents make it slightly lose its balance and turn slowly. VERTIGO seems to float, with the light on, it creates a pattern of shadows on the walls.* » CONSTANCE GUISSET

INFORMATIONS PRODUITS
PRODUCTS INFORMATIONS

PETIT / SMALL (NOIR / BLACK)



Reference : L0020301
 Reference : L0020601

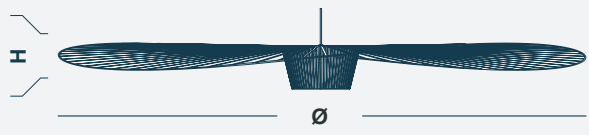



EAN : 3760236180071
 EAN : 3760236181368

Materials	Colours		Product	Ø	H	Packaging	L	W	H
Fibre de verre, fer, polyuréthane	Noir		cm	140	15	cm	72.5	72.5	21
Fiberglass, iron, polyurethane	Black		inch	55.1	5.9	inch	28.5	28.5	8.3

W: 0.5kg / 1.1 lb **W: 2.3 kg / 5 lb**

GRAND / LARGE (NOIR / BLACK)



Reference : L0020101
 Reference : L0020501

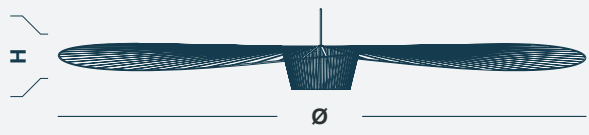

EAN : 3760236180033
 EAN : 3760236181320

Materials	Colours		Product	Ø	H	Packaging	L	W	H
Fibre de verre, fer, polyuréthane	Noir		cm	200	17	cm	72.5	72.5	21
Fiberglass, iron, polyurethane	Black		inch	78.7	6.7	inch	28.5	28.5	8.3

W: 0.5kg / 1.1 lb **W: 2.3 kg / 5 lb**

INFORMATIONS PRODUITS
PRODUCTS INFORMATIONS

PETIT / SMALL (VERT / GREEN)



Reference : **L0020302**
 Reference : **L0020602**

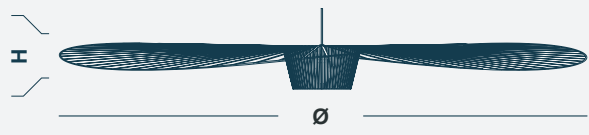

EAN : **3760236180088**
 EAN : **3760236181375**

Materials	Colours
Fibre de verre, fer, polyuréthane	Vert
Fiberglass, iron, polyurethane	Green

Product	Ø	H
cm	140	15
inch	55.1	5.9

Packaging	L	W	H
cm	72.5	72.5	21
inch	28.5	28.5	8.3

W: 0.5kg / 1.1 lb **W: 2.3 kg / 5 lb**

GRAND / LARGE (VERT / GREEN)



Reference : **L0020102**
 Reference : **L0020502**

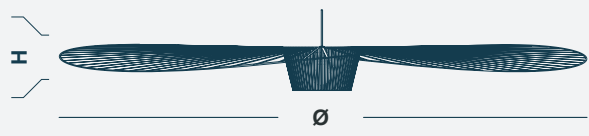

EAN : **3760236180040**
 EAN : **3760236181337**

Materials	Colours
Fibre de verre, fer, polyuréthane	Vert
Fiberglass, iron, polyurethane	Green

Product	Ø	H
cm	200	17
inch	78.7	6.7

Packaging	L	W	H
cm	72.5	72.5	21
inch	28.5	28.5	8.3

W: 0.5kg / 1.1 lb **W: 2.3 kg / 5 lb**

INFORMATIONS PRODUITS
PRODUCTS INFORMATIONS

PETIT / SMALL (CUIVRE / COPPER)



Reference : L0020304
 Reference : L0020604

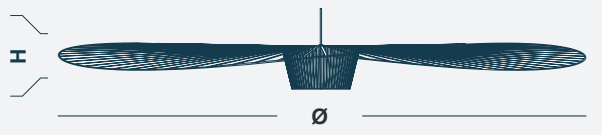

EAN : 3760236180095
 EAN : 3760236181382

Materials	Colours		Product	Ø	H	Packaging	L	W	H
Fibre de verre, fer, polyuréthane	Cuivre		cm	140	15	cm	72.5	72.5	21
Fiberglass, iron, polyurethane	Copper		inch	55.1	5.9	inch	28.5	28.5	8.3
			W: 0.5kg / 1.1 lb		W: 2.3 kg / 5 lb				

GRAND / LARGE (CUIVRE / COPPER)



Reference : L0020104
 Reference : L0020504

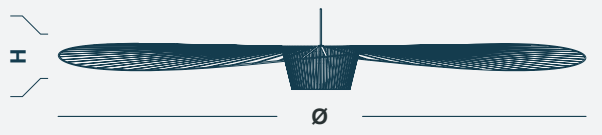



EAN : 3760236180057
 EAN : 3760236181344

Materials	Colours		Product	Ø	H	Packaging	L	W	H
Fibre de verre, fer, polyuréthane	Cuivre		cm	200	17	cm	72.5	72.5	21
Fiberglass, iron, polyurethane	Copper		inch	78.7	6.7	inch	28.5	28.5	8.3
			W: 0.5kg / 1.1 lb		W: 2.3 kg / 5 lb				

INFORMATIONS PRODUITS
PRODUCTS INFORMATIONS

PETIT / SMALL (BLANC / WHITE)



Reference : L0020305
 Reference : L0020605

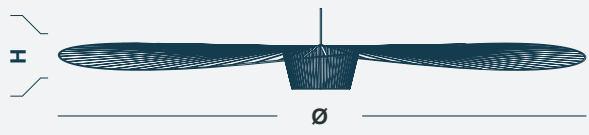

EAN : 3760236180101
 EAN : 3760236181399

Materials	Colours		Product	Ø	H	Packaging	L	W	H
Fibre de verre, fer, polyuréthane	Blanc		cm	140	15	cm	72.5	72.5	21
Fiberglass, iron, polyurethane	White		inch	55.1	5.9	inch	28.5	28.5	8.3
			W: 0.5kg / 1.1 lb		W: 2.3 kg / 5 lb				

GRAND / LARGE (BLANC / WHITE)



Reference : L0020105
 Reference : L0020505

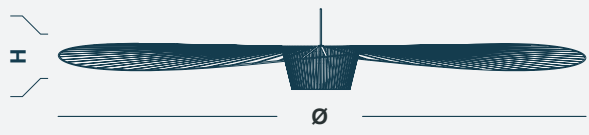



EAN : 3760236180064
 EAN : 3760236181351

Materials	Colours		Product	Ø	H	Packaging	L	W	H
Fibre de verre, fer, polyuréthane	Blanc		cm	200	17	cm	72.5	72.5	21
Fiberglass, iron, polyurethane	White		inch	78.7	6.7	inch	28.5	28.5	8.3
			W: 0.5kg / 1.1 lb		W: 2.3 kg / 5 lb				

INFORMATIONS PRODUITS
PRODUCTS INFORMATIONS

PETIT / SMALL (ROSE PASTEL / LIGHT PINK)



Reference : L0020306
 Reference : L0020606

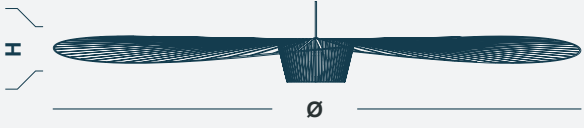

EAN : 3760236183249
 EAN : 3760236183324

Materials	Colours		Product	Ø	H	Packaging	L	W	H
Fibre de verre, fer, polyuréthane	Rose		cm	140	15	cm	72.5	72.5	21
Fiberglass, iron, polyurethane	Pink		inch	55.1	5.9	inch	28.5	28.5	8.3
			W: 0.5kg / 1.1 lb		W: 2.3 kg / 5 lb				

GRAND / LARGE (ROSE PASTEL / LIGHT PINK)



Reference : L0020106
 Reference : L0020506

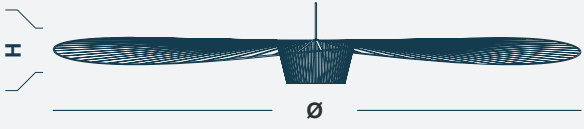

EAN : 3760236183225
 EAN : 3760236183300

Materials	Colours		Product	Ø	H	Packaging	L	W	H
Fibre de verre, fer, polyuréthane	Rose		cm	200	17	cm	72.5	72.5	21
Fiberglass, iron, polyurethane	Pink		inch	78.7	6.7	inch	28.5	28.5	8.3
			W: 0.5kg / 1.1 lb		W: 2.3 kg / 5 lb				

INFORMATIONS PRODUITS
PRODUCTS INFORMATIONS

PETIT / SMALL (BLEU PASTEL / LIGHT BLUE)



Reference : L0020307
 Reference : L0020607

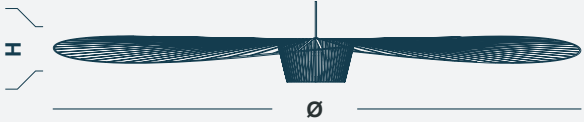

EAN : 3760236183256
 EAN : 3760236183331

Materials	Colours		Product	Ø	H	Packaging	L	W	H
Fibre de verre, fer, polyuréthane	Bleu		cm	140	15	cm	72.5	72.5	21
Fiberglass, iron, polyurethane	Blue		inch	55.1	5.9	inch	28.5	28.5	8.3

W: 0.5kg / 1.1 lb
W: 2.3 kg / 5 lb

GRAND / LARGE (BLEU PASTEL / LIGHT BLUE)



Reference : L0020107
 Reference : L0020507



EAN : 3760236183232
 EAN : 3760236183317

Materials	Colours		Product	Ø	H	Packaging	L	W	H
Fibre de verre, fer, polyuréthane	Bleu		cm	200	17	cm	72.5	72.5	21
Fiberglass, iron, polyurethane	Blue		inch	78.7	6.7	inch	28.5	28.5	8.3

W: 0.5kg / 1.1 lb
W: 2.3 kg / 5 lb

SPÉCIFICATIONS TECHNIQUES
TECHNICAL SPECIFICATIONS

EUROPE

- Environnement : intérieur /
Environment : indoor
- Fabriqué en Europe
(France) /
*Made in Europe
(France)*



• Norme CE / *CE mark*



• Puissance max /
Max power



• Base d'ampoule /
Base bulb



• Indice de protection /
Protection rating

• Puissance / Power :
220-240 V 50-60 Hz

• Ampoule non fournie /
Bulb not provided

• Câble textile, blanc ou
noir, 3 m / Fabric cable,
white or black, 3m

• Douille et plafonnier en
plastique blanc ou noir /
Socket and ceiling cup
white or black plastic

• Grand plafonnier inclus /
Large ceiling cup provided

• Ruban posé à la main /
*Two persons advised for
the folding / unfolding*

• Dépliage - pliage à 2
conseillé / Ribbon laid
by hand



SPÉCIFICATIONS TECHNIQUES
TECHNICAL SPECIFICATIONS

UK

- Environnement : intérieur /
Environment : indoor
- Fabriqué en Europe
(France) /
Made in Europe
(France)



• Norme CE / *CE mark*



• Puissance max /
Max power



• Base d'ampoule /
Base bulb



• Indice de protection /
Protection rating



• Cable U.K. / *U.K. cable*

• Puissance / Power :
220-240 V 50-60 Hz

• Ampoule non fournie /
Bulb not provided

• Câble textile, blanc ou
noir, 3 m / Fabric cable,
white or black, 3m

• Douille et plafonnier en
plastique blanc ou noir /
Socket and ceiling cup
white or black plastic

• Grand plafonnier inclus /
Large ceiling cup provided

• Ruban posé à la main /
*Two persons advised for
the folding / unfolding*

• Dépliage - pliage à 2
conseillé / Ribbon laid
by hand

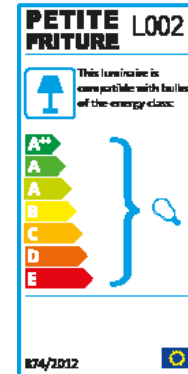

SPÉCIFICATIONS TECHNIQUES
TECHNICAL SPECIFICATIONS

NORTH AMERICA

- Environnement : intérieur /
Environment : indoor
- Fabriqué en Europe
(France) /
Made in Europe
(France)



- Norme UL / *UL mark*



- Puissance max /
Max power



- Base d'ampoule /
Base bulb



- Indice de protection /
Protection rating

- Puissance / Power
120 V 60 Hz

- Ampoule non fournie /
Bulb not provided

- Câble textile 3 m /
Coloured textile cable
of 3 m length

- Douille et plafonnier en
plastique blanc ou noir /
Socket and ceiling cup
white or black plastic.

- Grand plafonnier inclus /
Large ceiling cup provided

- Ruban posé à la main /
Two persons advised for
the folding / unfolding

- Dépliage - pliage à 2
conseillé / *Ribbon laid*
by hand

OPTIONS
SUR-MESURE

ÉCHANTILLONS DISPONIBLES SUR DEMANDE /
SAMPLES AVAILABLE ON REQUEST

POUR TOUTE INFORMATION COMPLÉMENTAIRE OU AUTRE DEMANDE,
N'HÉSITÉZ PAS À NOUS CONTACTER.

FOR ANY REQUEST OR FUTHER INFORMATION, PLEASE CONTACT US.

· | **CONTACT** | ·

PETITE FRITURE

Showroom

83 boulevard Richard Lenoir, 75011 - Paris

T +33 (0)1 44 54 13 95

F +33 (0)1 44 54 02 19

petitefriture.com

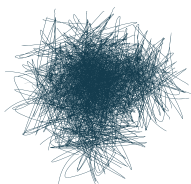

**PETITE
FRITURE**
ÉDITEUR DE DESIGN